

## Welding Manipulator

ProArc MP-1212 is designed specifically for TIG & MIG circumferential welding application. Combining with ProArc welding turntables or rollers, you can develop your own welding automation system and maximize your work efficiency.

### Features

- Rigid body structure
- Electrical boom lifting
- Manual boom travel control
- 360° base rotation<sup>\*1</sup> for flexible welding application
- Torch holder with dual X/Y axis torch slides fixed on ±90° rotating seat<sup>\*2</sup> for ease of movement in all direction

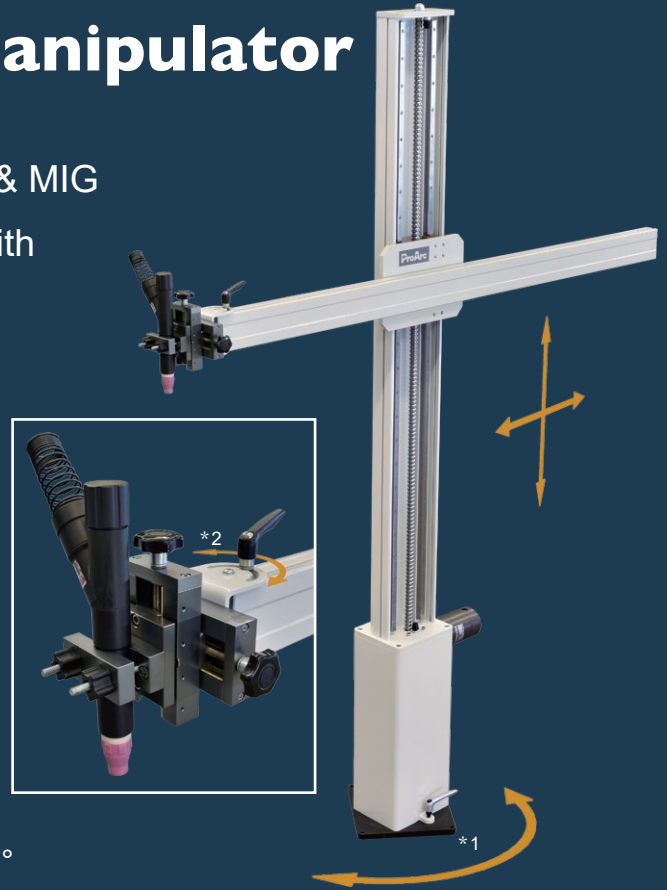

Model	Unit	MP-1212
Power input		1Ø 100~240VAC 50/60Hz
Stroke (E x F)	mm	1,200 x 1,200
Lifting adjustment	hp	1/12
Lifting speed	mm/min	950
Column rotation	deg	360 (Manual)
Dimension (A x B x C)	mm	2,070 x 1,700 x 300
Min. boom height from floor (D)	mm	600
Boom load capacity	kg	20

※ Specifications subject to change without notice.

### Dimensions

